

ULINE H-9725 BILLBOARD™ PLASTIC A-FRAME SIGN

1-800-295-5510
uline.com

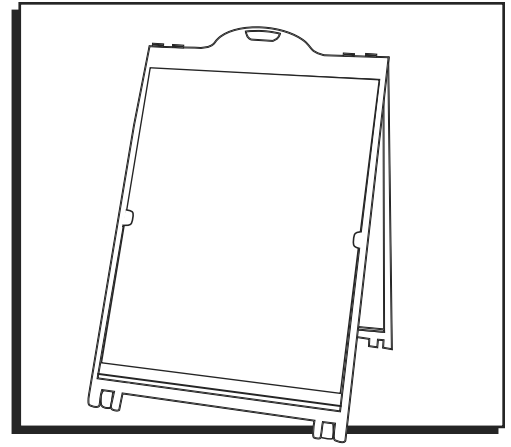

INSTRUCTIONS

MAIN SIGN INSERTION

1. Slide sign down through tabs until it rests on ground. (See Figures 1-2)

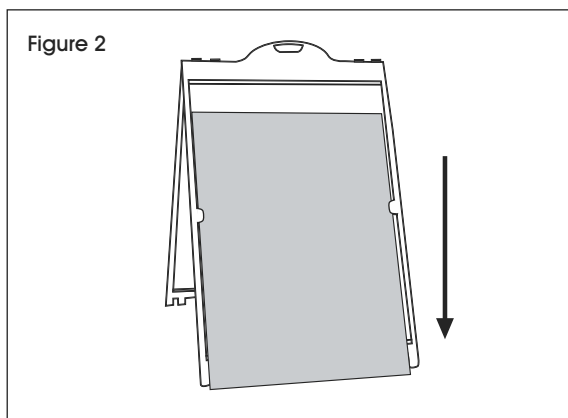
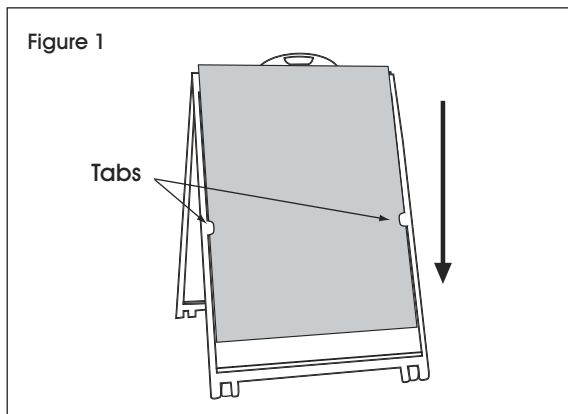

2. Push sign up into top slot. (See Figure 3)

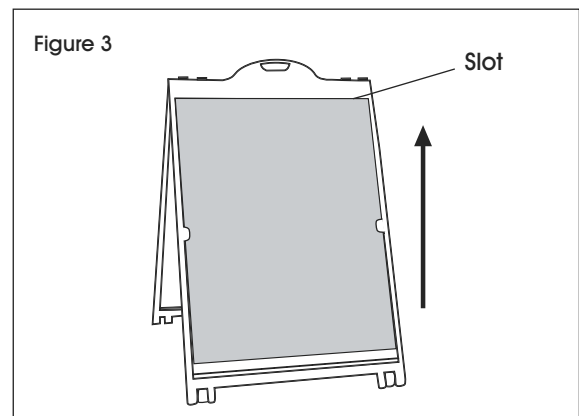

3. Slide sign down into bottom slot. (See Figure 4)

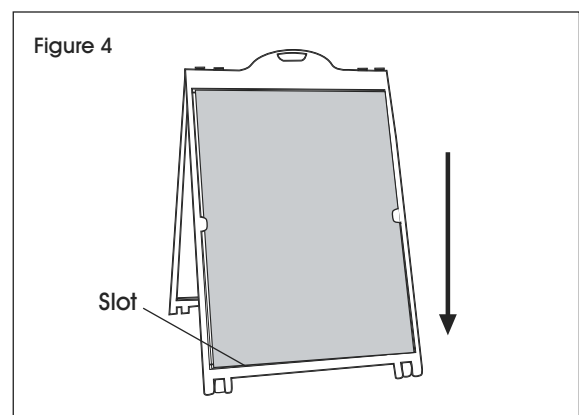

INSTRUCTIONS CONTINUED

TOP RIDER SIGN INSERTION

 **NOTE:** Insert top rider sign before inserting side signs.

1. Stand frame on ground, spreading sign faces open halfway.
2. Place rider sign in opening at top between sign faces. Move sign faces apart until fully extended. (See Figure 5)

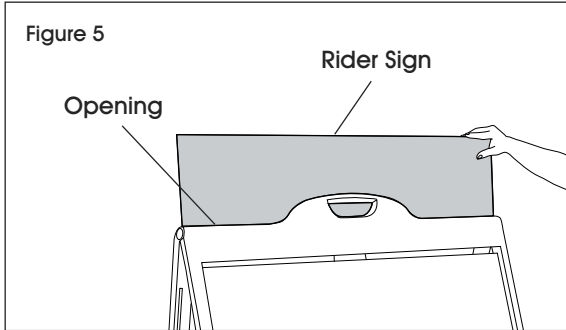

 **NOTE:** It is recommended to cut a hole in rider sign to make handle accessible.

SIDE SIGN INSERTION

 **NOTE:** If using corrugated plastic sheet for side signs, cut so flutes run horizontal.

1. Lay frame flat on ground. Lift up top sign face. (See Figure 6)

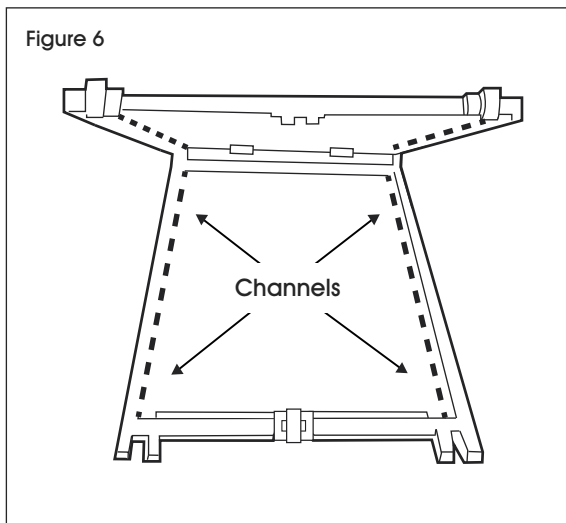

2. Slide first side sign into top and bottom channels on one side of frame. (See Figure 7)

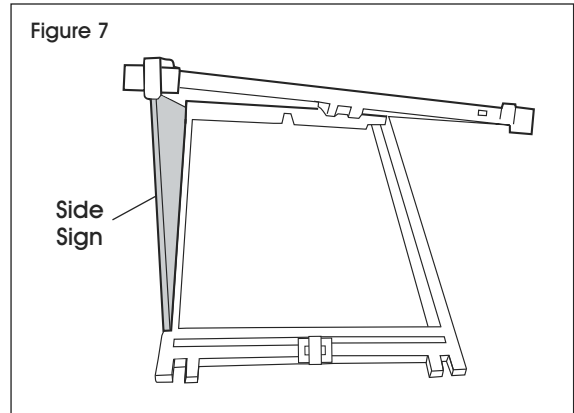

3. Slide second side sign into top and bottom channels on opposite side of frame. (See Figure 8)

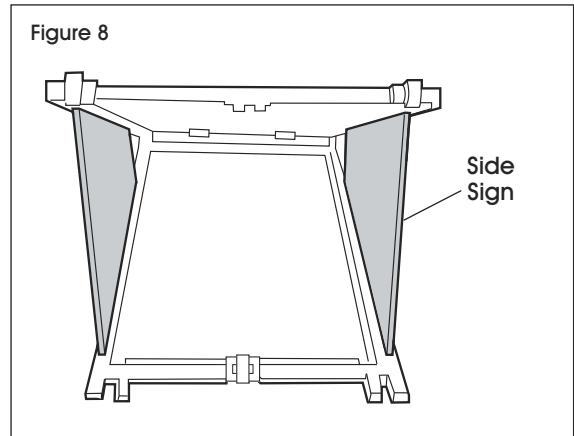

INSTRUCTIONS CONTINUED

STABILIZING THE SIGN

STABILIZING BAR

 **NOTE:** Use the stabilizing bar to prevent sign faces from spreading too far apart.

1. Insert stabilizing bar into hole on bottom of each sign face. (See Figures 9-10)

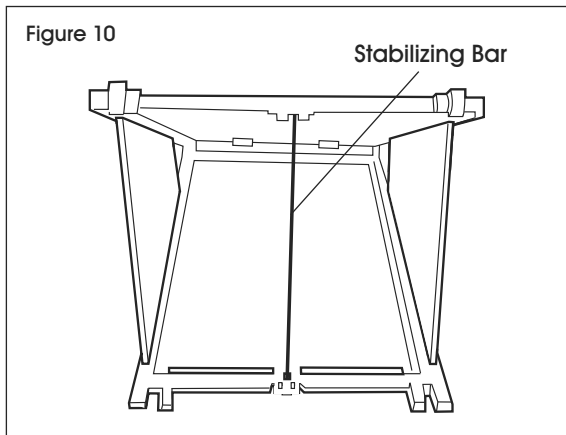
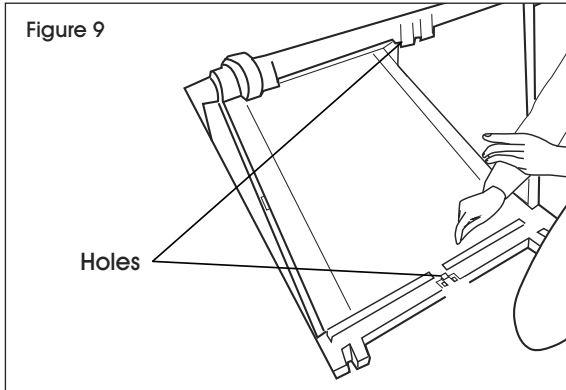

2. Lift up sign frame by handle to stand upright. (See Figure 11)

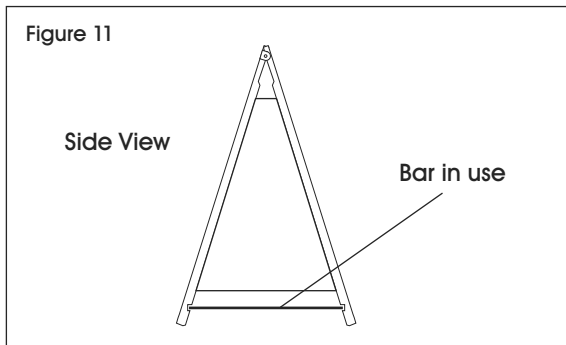

SAND BALLASTING

 **NOTE:** Each sign face has a hole on the side for filling the sign frame with sand.

1. Remove plug from hole. (See Figure 12)

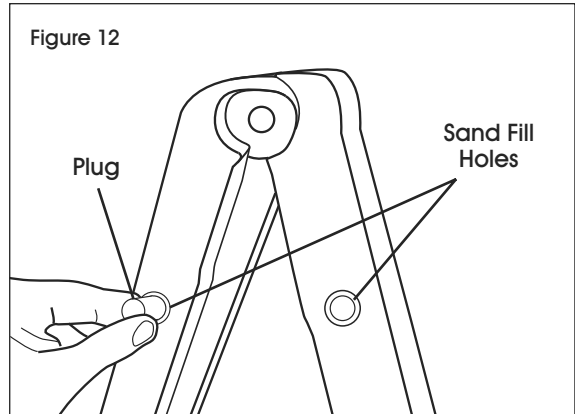

2. Fill with sand and replace plug. Repeat for second sign face.
3. Shake the sign frame to evenly distribute sand to bottom of frame.

 **NOTE:** 5 lbs. of sand per hole is recommended, for a total of 10 lbs.

 **NOTE:** Play sand is recommended for ease of filling.

ULINE H-9725

**BILLBOARD™ LETRERO
EN A DE PLÁSTICO**

800-295-5510
uline.mx

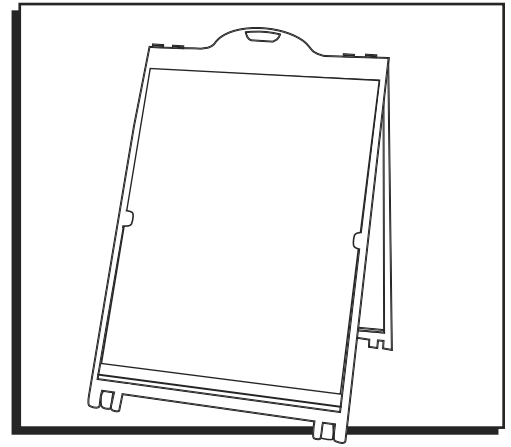

INSTRUCCIONES

COLOCACIÓN DEL LETRERO PRINCIPAL

1. Deslice el letrero hacia abajo a través de las pestañas hasta que se apoye en el suelo. (Vea Diagramas 1-2)

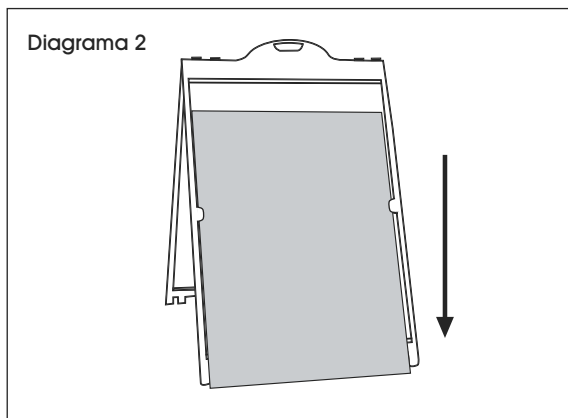
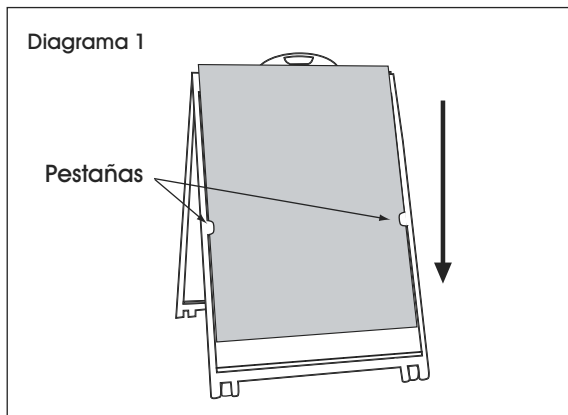

2. Empuje el letrero hacia arriba dentro de la ranura superior. (Vea Diagrama 3)

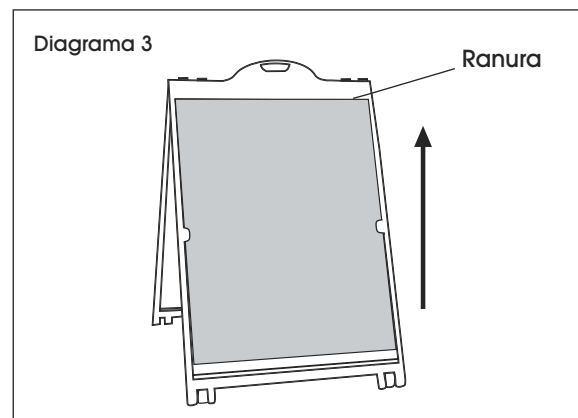

3. Deslice el letrero hacia abajo dentro de la ranura inferior. (Vea Diagrama 4)

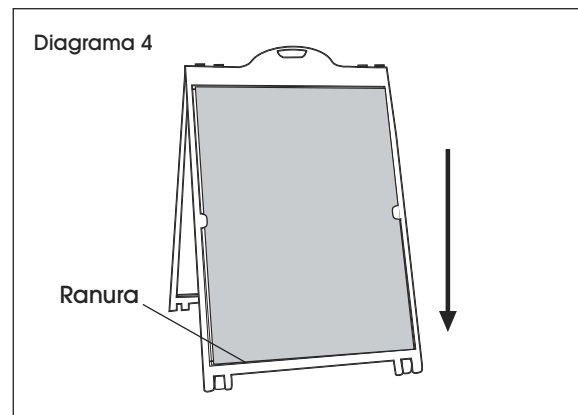

CONTINUACIÓN DE LAS INSTRUCCIONES

COLOCACIÓN DE LETRERO DE PANEL SUPERIOR

 **NOTA:** Inserte el letrero de panel superior antes de insertar los letreros laterales.

1. Coloque el armazón de pie sobre el suelo y despliegue las caras por la mitad.
2. Coloque el letrero de panel superior por encima entre las caras del letrero. Aparte las caras de los letreros hasta que estén completamente extendidas. (Vea Diagrama 5)

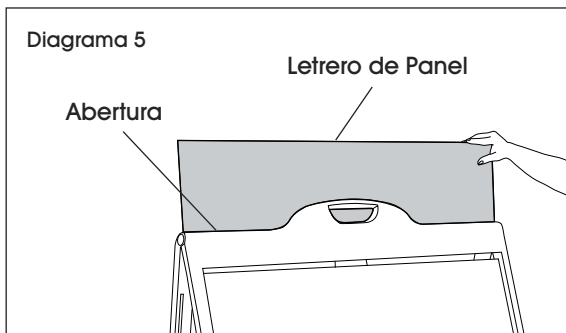

 **NOTA:** Se recomienda hacer un orificio en el letrero de panel para que se pueda usar el asa.

COLOCACIÓN DEL LETRERO LATERAL

 **NOTA:** Si utiliza una lámina de plástico corrugado para los letreros laterales, córtela de modo que las flautas corran horizontalmente.

1. Coloque el armazón plano sobre el suelo. Levante la cara superior del letrero. (Vea Diagrama 6)

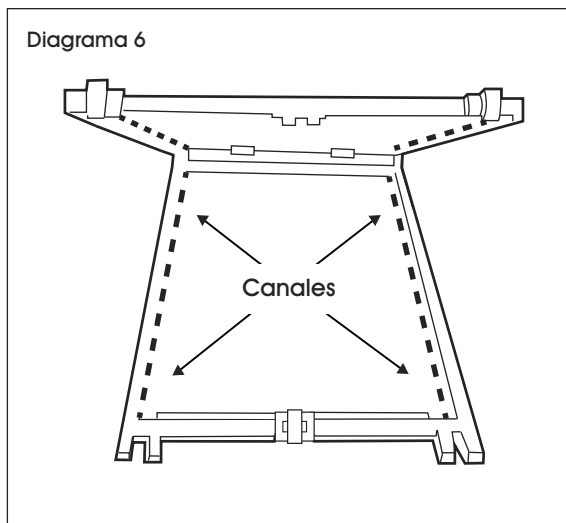

2. Deslice el primer letrero lateral en los canales superiores e inferiores en un lado del armazón. (Vea Diagrama 7)

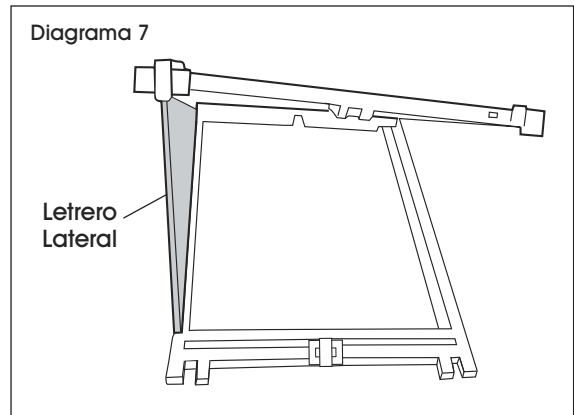

3. Deslice el segundo letrero lateral en los canales superiores e inferiores en el lado opuesto del armazón. (Vea Diagrama 8)

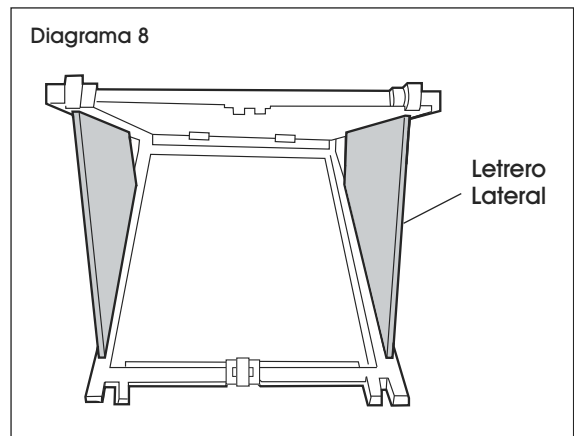

CONTINUACIÓN DE LAS INSTRUCCIONES

ESTABILIZACIÓN DEL LETRERO

BARRA ESTABILIZADORA

 **NOTA:** Use la barra estabilizadora para evitar que las caras del letrero se aparten demasiado.

1. Inserte la barra estabilizadora en el orificio en la parte inferior de cada cara del letrero. (Vea Diagramas 9-10)

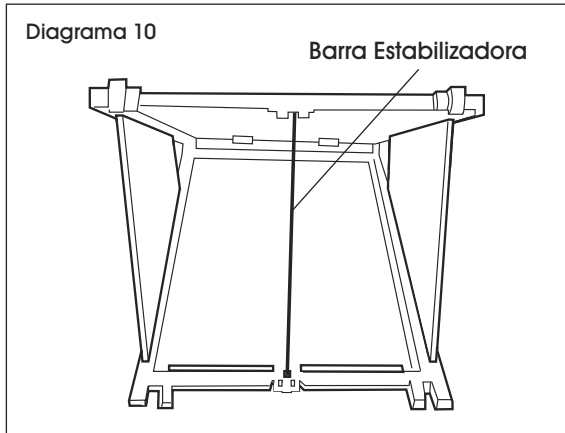
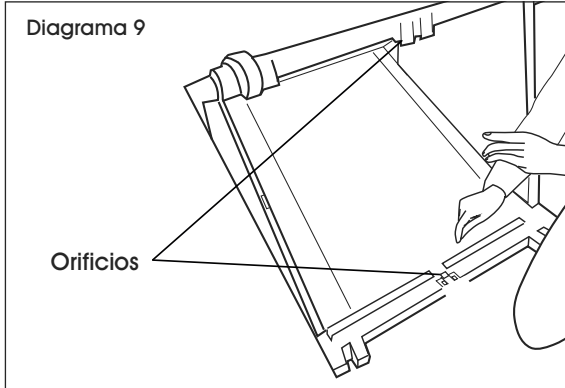

2. Levante el armazón del letrero por el asa para colocarlo de pie. (Vea Diagrama 11)

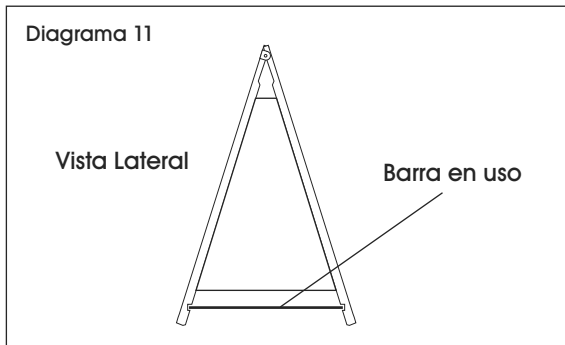

LASTRE DE ARENA

 **NOTA:** Cada cara del letrero cuenta con un orificio en el lado para llenar el armazón del letrero con arena.

1. Retire el tapón del orificio. (Vea Diagrama 12)

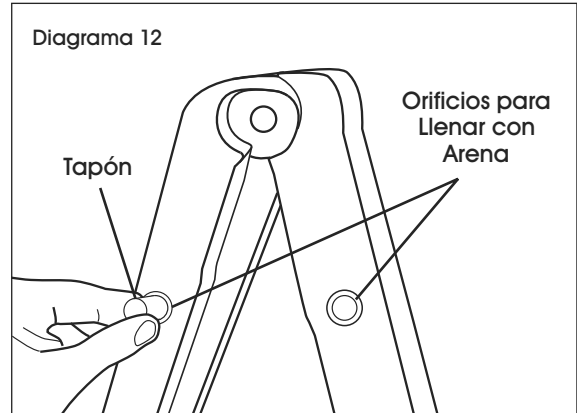

2. Llene con arena y vuelva a colocar el tapón. Repita la operación con la segunda cara del letrero.
3. Agite el armazón del letrero para distribuir la arena uniformemente a la parte inferior del armazón.

 **NOTA:** Se recomiendan 5 lbs. de arena por orificio para un total de 10 lbs.

 **NOTA:** Se recomienda arena para juegos para llenar fácilmente.

ULINE

800-295-5510
uline.mx

ULINE H-9725

**BILLBOARD^{MC} – ENSEIGNE
EN A EN PLASTIQUE**

1-800-295-5510
uline.ca

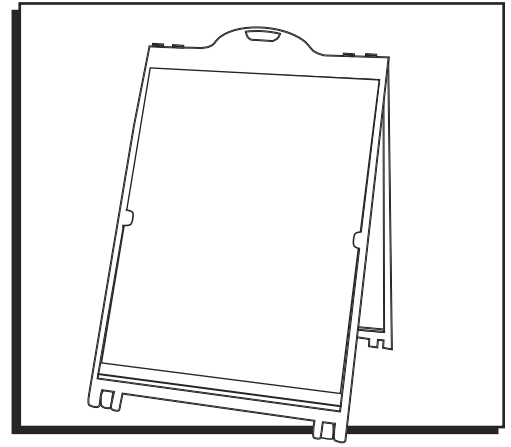

INSTRUCTIONS

INSERTION DE L'AFFICHE PRINCIPALE

1. Faites glisser l'affiche vers le bas à travers les languettes jusqu'à ce qu'elle touche le sol. (Voir Figures 1 et 2)

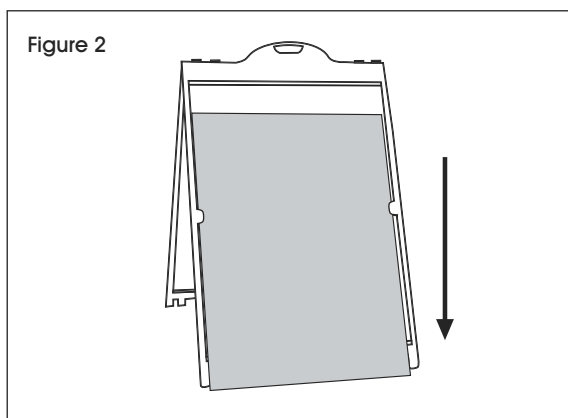
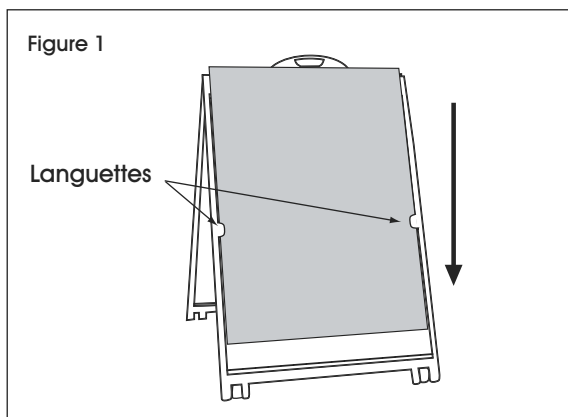

2. Poussez l'affiche vers le haut dans la fente supérieure. (Voir Figure 3)

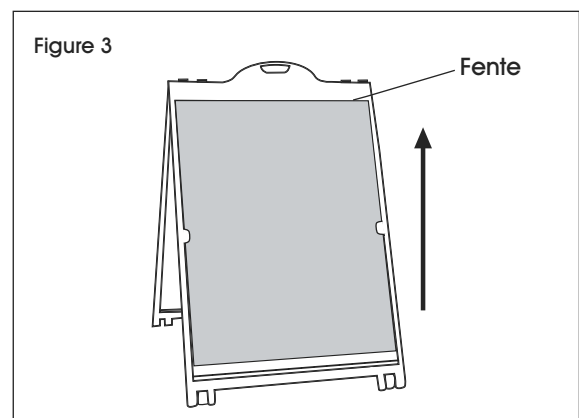

3. Glissez l'affiche vers le bas dans la fente inférieure. (Voir Figure 4)

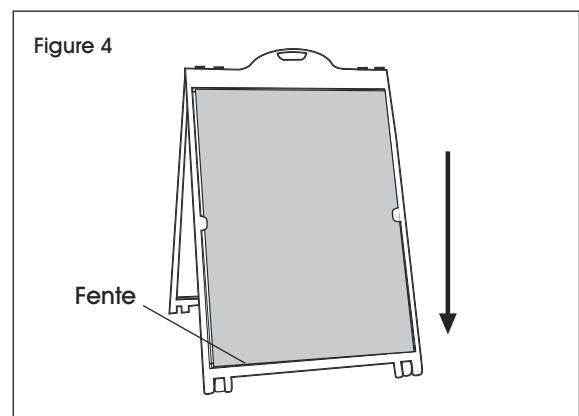

INSERTION DE L'AFFICHE SUPÉRIEURE

 **REMARQUE :** Insérez l'affiche supérieure avant de procéder aux affiches latérales.

1. Placez le cadre au sol et écartez les deux faces de moitié.
2. Placez l'affiche supérieure dans l'ouverture entre les deux faces. Écartez-les jusqu'à étirement complet. (Voir Figure 5)

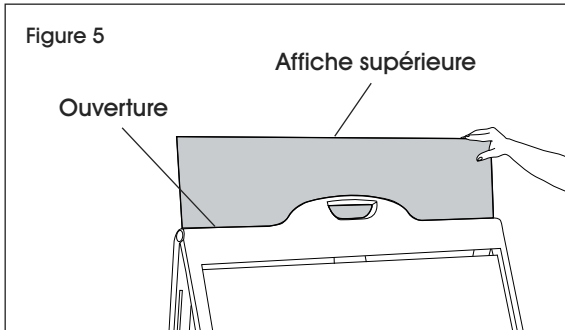

 **REMARQUE :** Il est recommandé de faire un trou dans l'affiche pour faciliter l'accès à la poignée.

INSERTION DES AFFICHES LATÉRALES

 **REMARQUE :** Si vous utilisez des feuilles en plastique ondulé pour les affiches latérales, découpez-les de manière à ce que les cannelures se trouvent dans le sens horizontal.

1. Placez le cadre à plat sur le sol. Soulevez la face supérieure de l'enseigne. (Voir Figure 6)

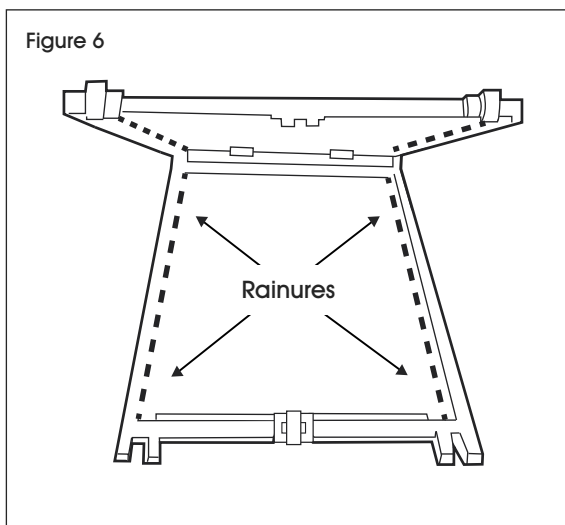

2. Glissez l'affiche latérale dans les rainures supérieures et inférieures sur l'un des côtés du cadre. (Voir Figure 7)

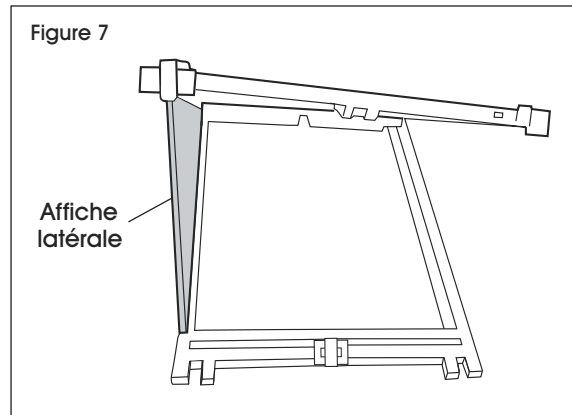

3. Glissez l'autre affiche latérale dans les rainures supérieures et inférieures sur l'autre côté du cadre. (Voir Figure 8)

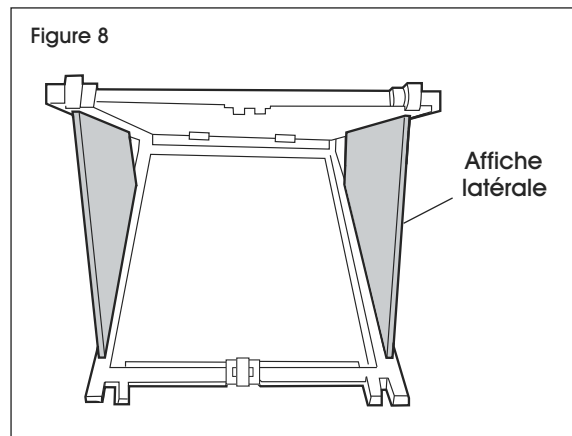

INSTRUCTIONS SUITE

RENFORCEMENT DE L'ENSEIGNE

BARRE DE RENFORCEMENT

 **REMARQUE :** Servez-vous de la barre de renforcement pour éviter que les faces soient trop écartées.

1. Insérez la barre de renforcement dans le trou situé au bas des deux faces. (Voir Figures 9 et 10)

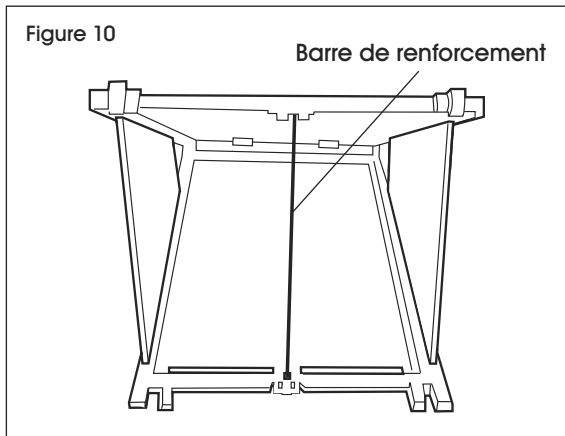
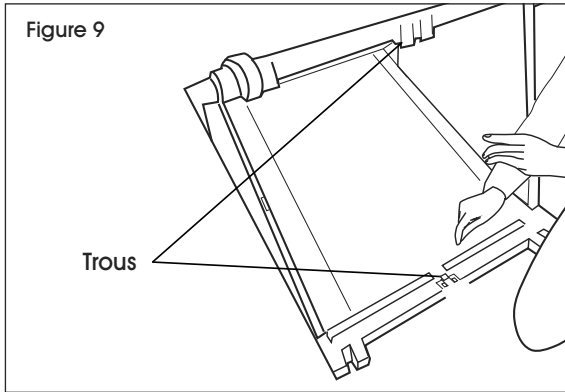

2. Soulevez le cadre de l'enseigne par la poignée pour le redresser. (Voir Figure 11)

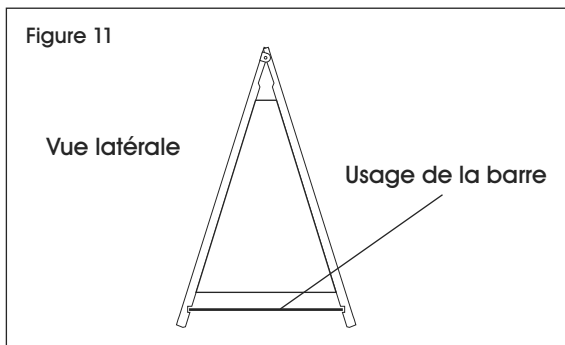

LESTAGE AVEC DU SABLE

 **REMARQUE :** Chacune des faces de l'enseigne dispose d'un orifice sur le côté servant à remplir le cadre de sable.

1. Retirez le bouchon de l'orifice. (Voir Figure 12)

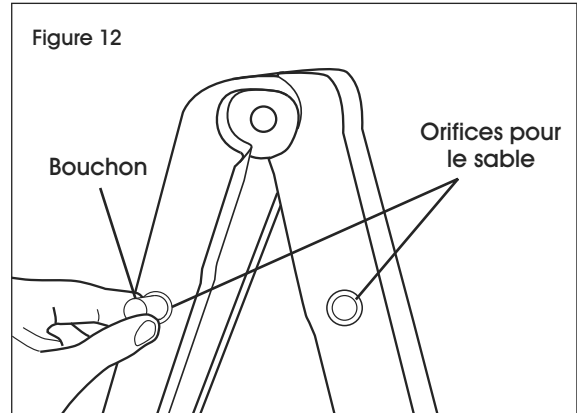

2. Remplissez le cadre avec du sable et replacez le bouchon. Répétez l'opération sur l'autre face.
3. Secouez le cadre pour bien répartir le sable au fond du cadre.

 **REMARQUE :** Il est recommandé de verser 5 lb par orifice pour un total de 10 lb de sable.

 **REMARQUE :** Il est recommandé d'utiliser du sable de jeu qui est plus simple à verser.

ULINE

1-800-295-5510
uline.ca